

Warm Up Grade 8

May 27



Whenever 3 dimensions are given, they are in the order: length, width and height.

Assessment Review

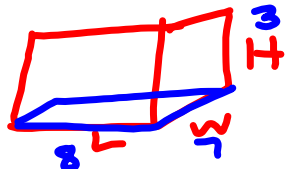

Don't paint Floor/Ceiling $L \times W$



Sarah paints the walls of her bed room. The room measures 8 m by 7 m by 3 m. One can will cover 35 m^2 .

a) How much paint should she buy if she needs to put 2 coats on the walls?

Floor/Ceiling

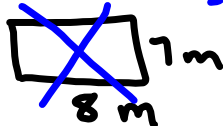

Front/Back

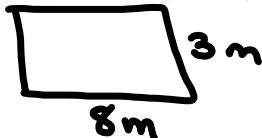

$$A = L \times W \\ = 8 \text{ m} \times 3 \text{ m} \\ = 24 \text{ m}^2$$

$$\times 2 \text{ walls} \\ \hline 48 \text{ m}^2$$

Left/Right

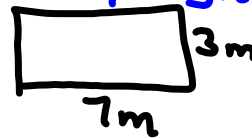

$$A = L \times W \\ = 7 \text{ m} \times 3 \text{ m} \\ = 21 \text{ m}^2$$

$$\times 2 \text{ walls} \\ \hline 42 \text{ m}^2$$

$$\text{Total SA walls} = 90 \text{ m}^2$$

$\times 2 \text{ coats}$

180 m^2 of paint needed

$$\text{Cans of paint} = 180 \text{ m}^2 \div 35 \text{ m}^2 \\ = 5.14 \text{ cans}$$

Buy 6 cans

Mental Math

1) 24×25

half double
 12×50
600

2) 9.5×0.1

$9.5 \times \frac{1}{10}$
like \div by 10
move decimal
0.95

3) $5 \times 13.6 \times 20$

$5 \times 20 \times 13.6$
 100×13.6
1360

6c)

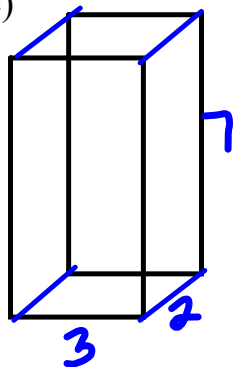

$$A = l \times w$$

$$= 7 \times 3$$

$$= 21 \text{ cm}^2$$

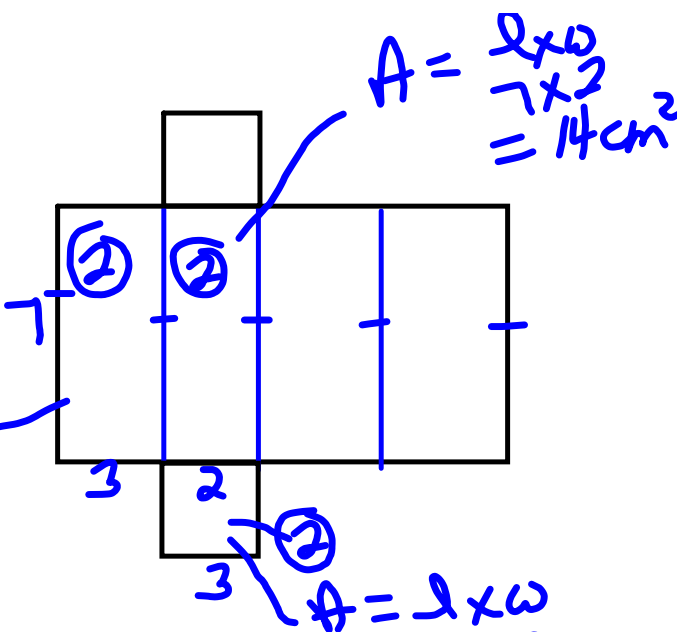

$$A = l \times w$$

$$= 3 \times 2$$

$$= 6 \text{ cm}^2$$

$$SA = 2 \times 21 + 2 \times 14 + 2 \times 6$$

$$= 42 + 28 + 12$$

$$= 82 \text{ cm}^2$$

top/bottom

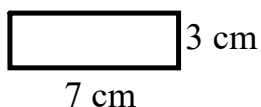

$$A = l \times w$$

$$= 7 \text{ cm} \times 3 \text{ cm}$$

$$= 21 \text{ cm}^2$$

side/side

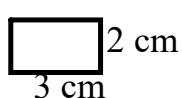

$$A = l \times w$$

$$= 2 \text{ cm} \times 3 \text{ cm}$$

$$= 6 \text{ cm}^2$$

front/back

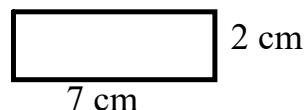

$$A = l \times w$$

$$= 2 \text{ cm} \times 7 \text{ cm}$$

$$= 14 \text{ cm}^2$$

$$\text{Total SA} = 2 (\text{Top}) + 2 (\text{Side}) + 2 (\text{Front})$$

$$= 2 (21 \text{ cm}^2) + 2 (6 \text{ cm}^2) + 2 (14 \text{ cm}^2)$$

$$= 42 \text{ cm}^2 + 12 \text{ cm}^2 + 28 \text{ cm}^2$$

$$= 82 \text{ cm}^2$$

7a)

top/bottom

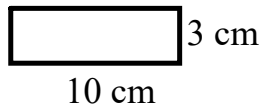

$$A = l \times w$$

$$= 10 \text{ cm} \times 3 \text{ cm}$$

$$= 30 \text{ m}^2$$

side/side

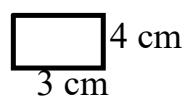

$$A = l \times w$$

$$= 4 \text{ cm} \times 3 \text{ cm}$$

$$= 12 \text{ m}^2$$

front/back

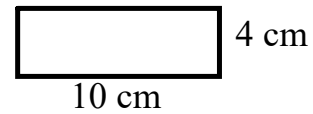

$$A = l \times w$$

$$= 10 \text{ cm} \times 4 \text{ cm}$$

$$= 40 \text{ m}^2$$

$$\text{Total SA} = 2 (\text{Top}) + 2 (\text{Side}) + 2 (\text{Front})$$

$$= 2 (30 \text{ m}^2) + 2 (12 \text{ m}^2) + 2 (40 \text{ m}^2)$$

$$= 60 \text{ m}^2 + 24 \text{ m}^2 + 80 \text{ m}^2$$

$$= 164 \text{ m}^2$$

7b)

top/bottom

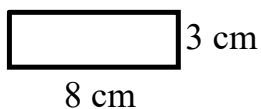

$$A = l \times w$$

$$= 8 \text{ cm} \times 3 \text{ cm}$$

$$= 24 \text{ cm}^2$$

side/side

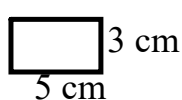

$$A = l \times w$$

$$= 5 \text{ cm} \times 3 \text{ cm}$$

$$= 15 \text{ cm}^2$$

front/back

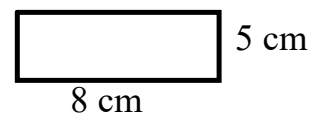

$$A = l \times w$$

$$= 5 \text{ cm} \times 8 \text{ cm}$$

$$= 40 \text{ cm}^2$$

$$\text{Total SA} = 2 (\text{Top}) + 2 (\text{Side}) + 2 (\text{Front})$$

$$= 2 (24 \text{ cm}^2) + 2 (15 \text{ cm}^2) + 2 (40 \text{ cm}^2)$$

$$= 48 \text{ cm}^2 + 30 \text{ cm}^2 + 80 \text{ cm}^2$$

$$= 158 \text{ cm}^2$$

Whenever 3 dimensions are given, they are in the order:
length, width and height.

9)

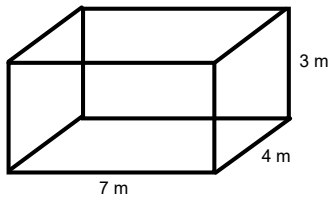

The walls are being painted.

b) Assume you don't include ceiling and floor

side/side

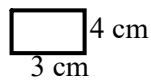

front/back

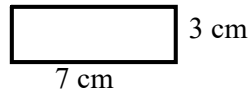

$$\begin{aligned} A &= l \times w \\ &= 4 \text{ cm} \times 3 \text{ cm} \\ &= 12 \text{ m}^2 \end{aligned}$$

$$\begin{aligned} A &= l \times w \\ &= 7 \text{ cm} \times 3 \text{ cm} \\ &= 21 \text{ m}^2 \end{aligned}$$

$$\begin{aligned} \text{Total SA Walls} &= 2 (\text{Side}) + 2 (\text{Front}) \\ &= 2 (12 \text{ m}^2) + 2 (21 \text{ m}^2) \\ &= 24 \text{ m}^2 + 42 \text{ m}^2 \\ &= 66 \text{ m}^2 \end{aligned}$$

$$\begin{aligned} \text{Need 2 coats so need to cover twice the area} &= 2 \times 66 \text{ m}^2 \\ &= 132 \text{ m}^2 \end{aligned}$$

1 can covers 40 m²

$$132 / 40 = 3.3 \text{ cans}$$

Need to buy 4 cans

10) All 6 sides of a cube have equal area so

$$\begin{aligned} \text{a) Area of one face of a cube} &= 54 \text{ cm}^2 / 6 \\ &= 9 \text{ cm}^2 \end{aligned}$$

$$\text{b) Area of square} = 9 \text{ cm}^2$$

$$\text{side} = \sqrt{9}$$

$$\text{side} = 3 \text{ cm}$$

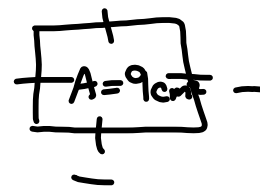

Ch. 1

$$\text{Side} = \sqrt{\text{Area}}$$

Whenever 3 dimensions are given, they are in the order:
length, width and height.

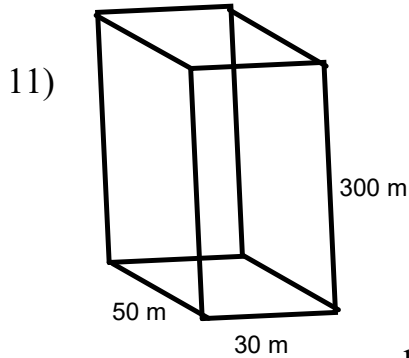

b) Assume you don't include ceiling and floor

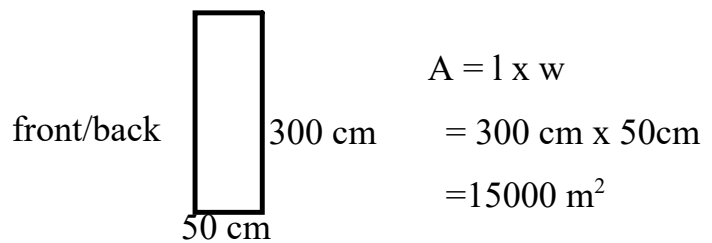
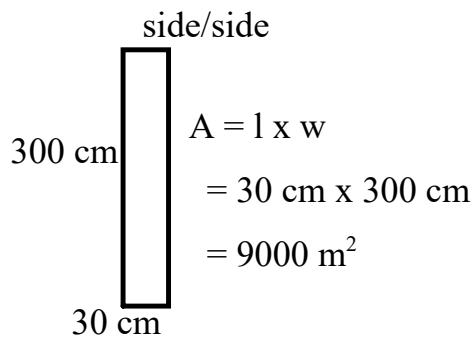

$$\begin{aligned}
 \text{Total SA Walls} &= 2 (\text{Side}) + 2 (\text{Front}) \\
 &= 2 (9000 \text{ m}^2) + 2 (15000 \text{ m}^2) \\
 &= 18000 \text{ m}^2 + 30000 \text{ m}^2 \\
 &= 48000 \text{ m}^2
 \end{aligned}$$

Only 1/4 are windows

$$\frac{48000 \text{ m}^2}{4} = 12000 \text{ m}^2 \rightarrow \text{window}$$

SO $48000 - 12000$
 36000 m^2
 available

12)

12.

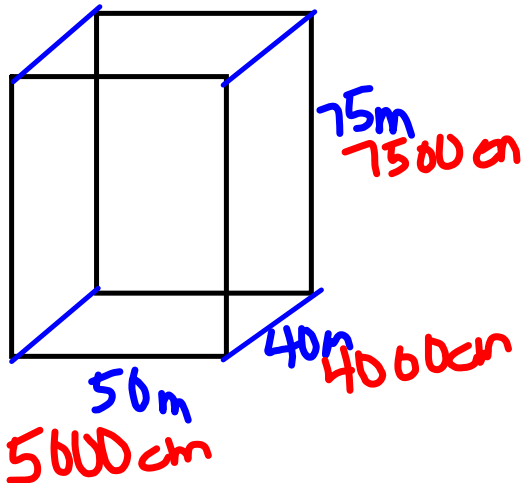
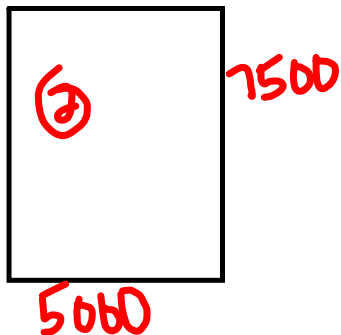
Find area of
4 walls.

$$A = l \times w$$

$$= 7500 \times 5000$$

$$= 375\,000\,000\text{ cm}^2$$

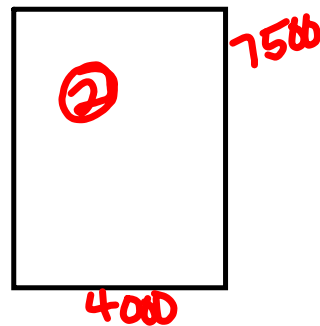

$$A = l \times w$$

$$= 7500 \times 4000$$

$$= 300\,000\,000\text{ cm}^2$$

$$\text{Total Area} = 2 \times 375\,000\,000 + 2 \times 300\,000\,000$$

$$= 750\,000\,000 + 600\,000\,000$$

$$= 1\,350\,000\,000\text{ cm}^2$$

1 Euro per month for every 50 cm^2

$$\frac{1\,350\,000\,000}{50}$$

27 000 000 Euros per month
for advertising

13 a)

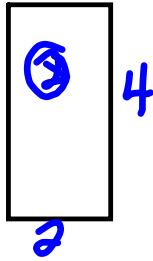
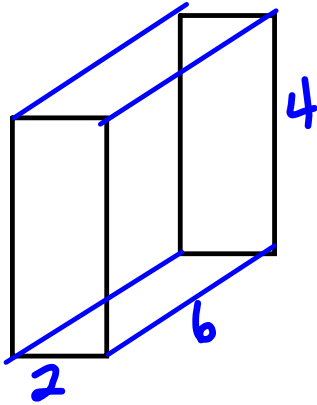

$$A = l \times w \\ = 4 \times 2 \\ = 8 \text{ cm}^2$$



$$A = l \times w \\ = 6 \times 2 \\ = 12 \text{ cm}^2$$

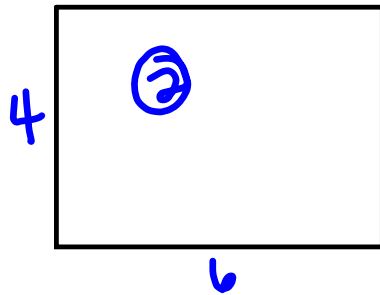

$$A = l \times w \\ = 6 \times 4 \\ = 24 \text{ cm}^2$$

$$SA = 2 \times 8 + 2 \times 12 + 2 \times 24 \\ = 16 + 24 + 48 \\ = 88 \text{ cm}^2$$

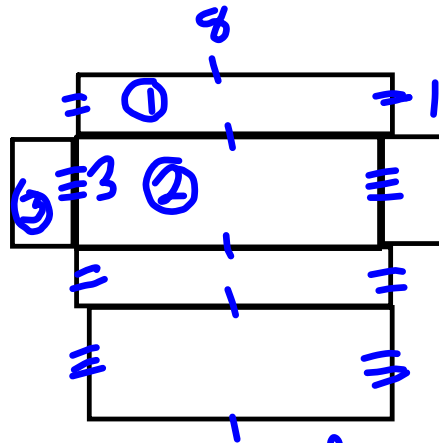
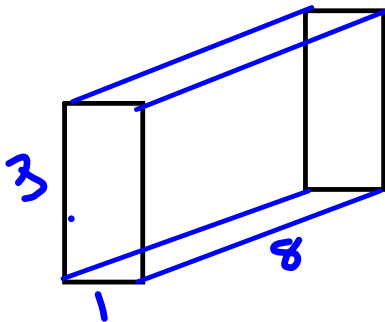

$$A_1 = l \times w \\ = 8 \times 1 \\ = 8 \text{ cm}^2$$

$$A_2 = l \times w \\ = 8 \times 3 \\ = 24 \text{ cm}^2$$

$$A_3 = l \times w \\ = 3 \times 1 \\ = 3 \text{ cm}^2$$

$$SA = 2 \times 8 + 2 \times 24 + 2 \times 3 \\ = 16 + 48 + 6 \\ = 70 \text{ cm}^2$$

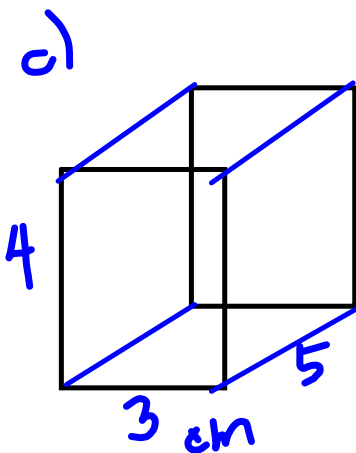

Front & Back

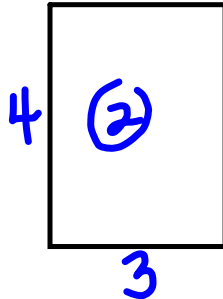

$$A = l \times w$$

$$= 4 \times 3$$

$$= 12 \text{ cm}^2$$

Sides

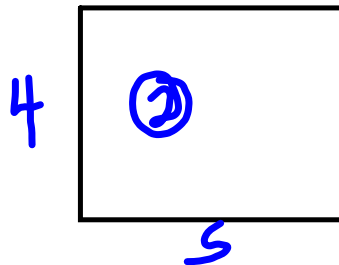

$$A = l \times w$$

$$= 4 \times 5$$

$$= 20 \text{ cm}^2$$

Top and Bottom

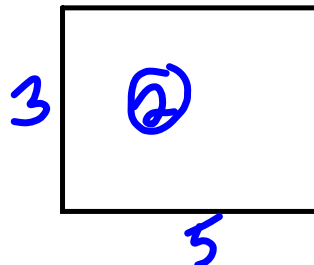

$$A = l \times w$$

$$= 5 \times 3$$

$$= 15 \text{ cm}^2$$

$$SA = 2 \times 12 + 2 \times 20 + 2 \times 15$$

$$= 24 + 40 + 30$$

$$= 94 \text{ cm}^2$$

Greatest SA	3x4x5	Prism R
Least SA	1x3x8	Prism Q

14.

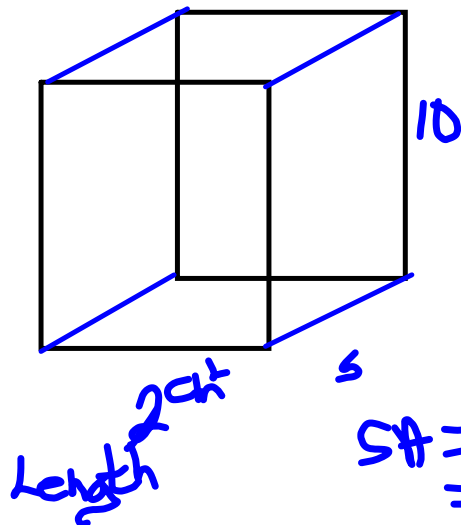

$$A - \text{Top \& Bottom} \\ = 2 \times 5 = 10$$

$$A - \text{Sides} \\ 10 \times 5 = 50$$

$$A - \text{Front \& Back} \\ 10 \times 2 = 20$$

$$SA = 2 \times 10 + 2 \times 50 + 2 \times 20 \\ = 20 + 100 + 40 \\ = 160 \text{ cm}^2$$

a) Double the length $\rightarrow 4 \text{ cm}$

Area of sides stayed the same $\rightarrow 50 \text{ cm}^2$

$$\text{Top \& Bottom} \rightarrow 4 \times 5 = 20 \text{ cm}^2$$

$$\text{Front \& Back} \rightarrow 4 \times 10 = 40 \text{ cm}^2$$

$$SA = 2 \times 50 + 2 \times 20 + 2 \times 40 \\ = 100 + 40 + 80 = 220 \text{ cm}^2$$

b) Half the length

Area of Sides \rightarrow same 50 cm^2

$$T \& B \rightarrow 1 \times 5 = 5 \text{ cm}^2$$

$$F \& B \rightarrow 1 \times 10 = 10 \text{ cm}^2$$

$$SA = 2 \times 50 + 2 \times 5 + 2 \times 10 \\ = 100 + 10 + 20 \\ = 130 \text{ cm}^2$$

16. Square Base $4m^2$
Surface Area $48m^2$

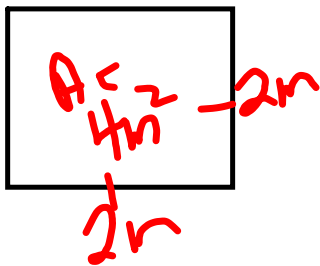

Both bases $\rightarrow 8m^2$

4 sides \rightarrow have an area $40m^2$
($48 - 8$)

one of lengths 2m

Each of rectangles is the same,
so area of each rectangle $\frac{40}{4} = 10m^2$

$$2 \times \underline{\quad} = 10$$

Dimensions $2 \times 2 \times 5$

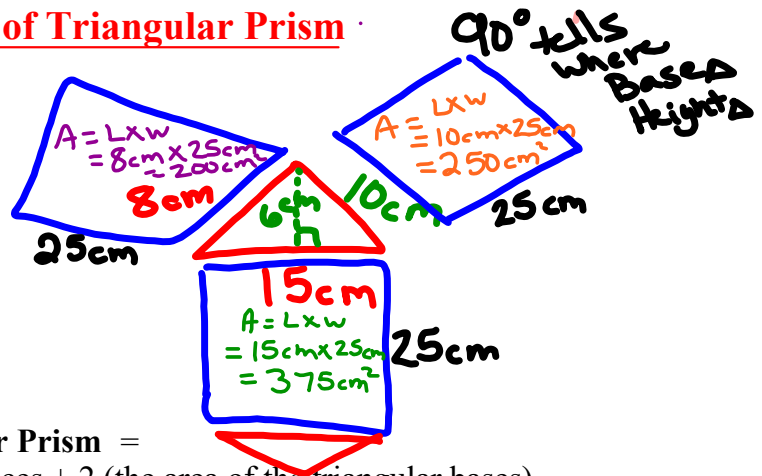
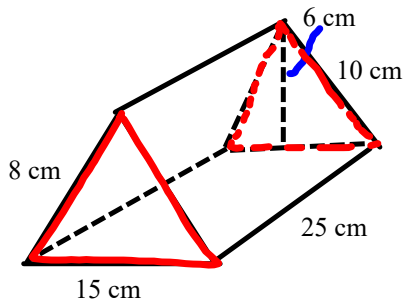
Surface Area of Triangular Prism

The Surface Area of a Triangular Prism =
areas of the 3 rectangular faces + 2 (the area of the triangular bases)

- Sketch the faces (HINT start with the Triangle)

$$\begin{aligned}
 A_{\Delta} &= \frac{b \times h}{2} \\
 &= \frac{15 \text{ cm} \times 6 \text{ cm}}{2} \\
 &= \frac{90 \text{ cm}^2}{2} \\
 &= 45 \text{ cm}^2
 \end{aligned}$$

$$\begin{aligned}
 \text{Total SA}_{\Delta \text{pris}} &= \square + \square + \square + 2\Delta \\
 &= 200 \text{ cm}^2 + 375 \text{ cm}^2 + 250 \text{ cm}^2 + 2(45 \text{ cm}^2) \\
 &= 200 \text{ cm}^2 + 375 \text{ cm}^2 + 250 \text{ cm}^2 + 90 \text{ cm}^2 \\
 &= 915 \text{ cm}^2
 \end{aligned}$$

Surface Area of Triangular Prism

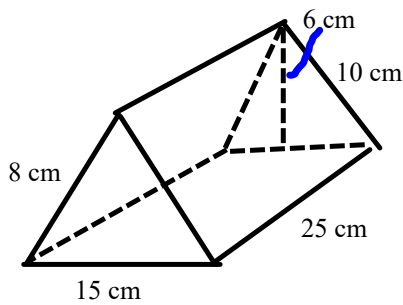

Front and Back

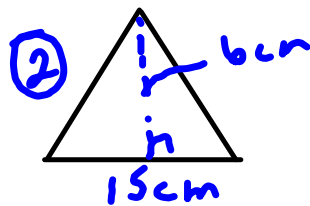

$$\begin{aligned}
 A &= \frac{b \times h}{2} \\
 &= \frac{15 \times 6}{2} \\
 &= \frac{90}{2} \\
 &= 45 \text{ cm}^2
 \end{aligned}$$

Bottom



$$\begin{aligned}
 A &= l \times w \\
 &= 25 \times 15 \\
 &= 375 \text{ cm}^2
 \end{aligned}$$

Side

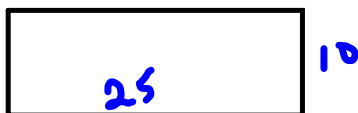

$$\begin{aligned}
 A &= l \times w \\
 &= 25 \times 10 \\
 &= 250 \text{ cm}^2
 \end{aligned}$$

Side

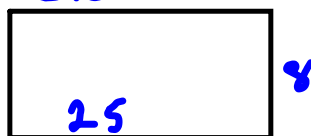

$$\begin{aligned}
 A &= l \times w \\
 &= 25 \times 8 \\
 &= 200 \text{ cm}^2
 \end{aligned}$$

$$\begin{aligned}
 SA &= 2 \times 45 + 375 + 250 + 200 \\
 &= 90 + 375 + 250 + 200 \\
 &= 915 \text{ cm}^2
 \end{aligned}$$

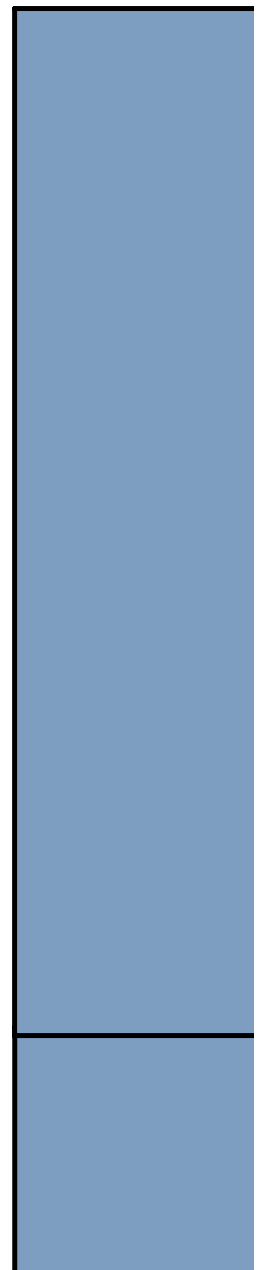

The Surface Area of a Triangular Prism equals the sum of the areas of the 3 rectangular faces + 2 x the area of the triangular bases.

Class/Homework

$$A_{\Delta} = \frac{b \times h}{2}$$

Page 191

~~#4 #5~~, #6 #7a,

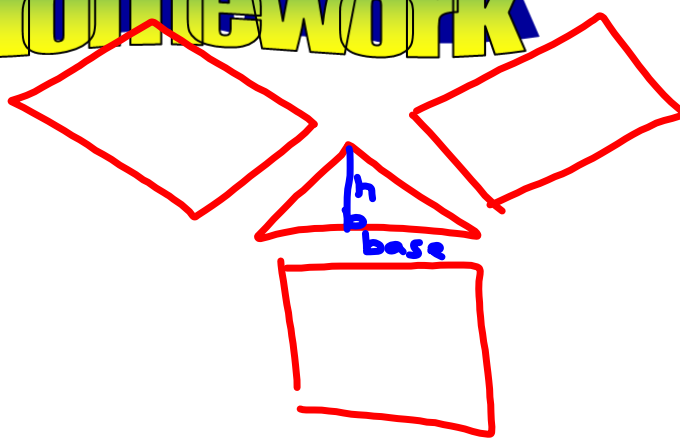

Sketch a net of this right triangular prism.
What is its surface area?

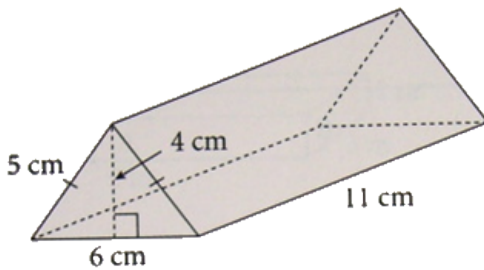

Sketch a net of this right triangular prism.
What is its surface area?

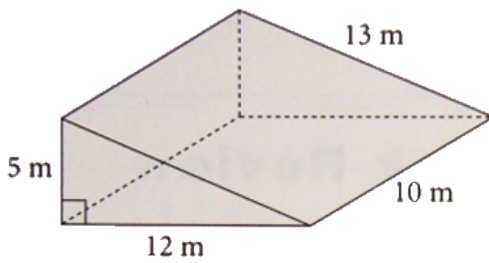

Sketch a net of this right triangular prism.
What is its surface area?

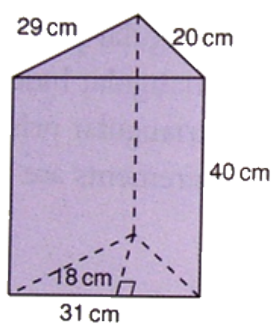

Attachments

Review of Surface area of 2D Shape Grade 8 Unit 4 PDF.pdf